

IGNITE

TECHNICAL MAGAZINE

Department of Electrical and Electronics Engineering

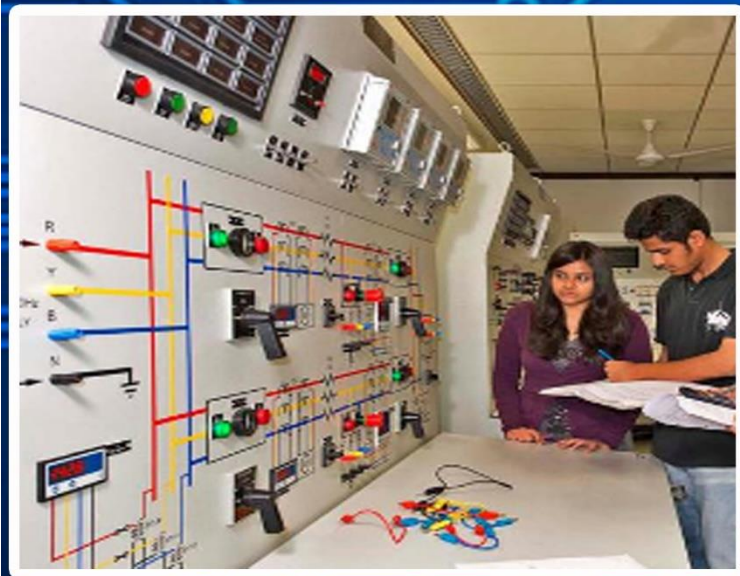

Volume 10 Issue 1
2022-2023

Gnanamani College of Technology

Accredited by NAAC 'A' Grade and NBA

NH-7, A.K.Samuthiram, Pachal-PO, Namakkal-637 018, Tamil Nadu.

www.gct.org.in

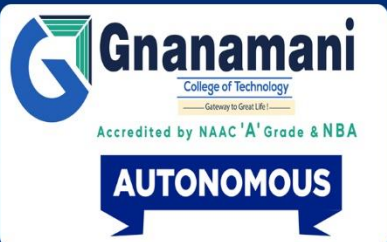

IGNITE

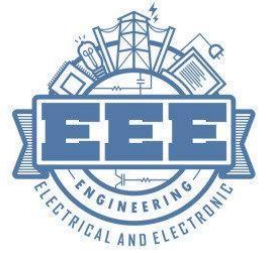

Technical magazine

It is to provide a platform for the students, teachers, technical as well as non-technical staff of the college to express their work, ideas, views, opinions, etc. related to science and technology. They provide a platform for faculty and students to publish articles, share technical expertise, and highlight achievements, ultimately driving awareness of recent trends and enhancing technical skills.

Editorial Board

Faculty Coordinator:

- Dr.J.Chandramohan HOD/EEE
- Mr.K.Satheeshkumar AP/EEE

Student Coordinator:

- Sankar C
- Geetha C
- Prema M
- Yogeshkumar G
- Kamalesh K



Gnanamani College of Technology
(Approved By AICTE & Affiliated to Anna University, Chennai)
Accredited By NAAC "A" Grade & NBA
NH-7, A Samuthiram, Pachal (P.O.), Namakkal - 637018
Department of Mechanical Engineering

GNANAMANI EDUCATIONAL INSTITUTIONS

Gnyanamani Educational Institutions that have carved a niche for itself in the field of engineering education within a very short span of time. Gnanamani College of Technology which was established in the year 2006, the group comprises of Gnanamani College of Education, established in the year 2005.

Gnanodaya CBSE International School was established in the year 2015. These Institutions serve under the aegis of The Christian Educational Development Trust.

Gnyanamani Educational Institutions were established in a well-planned campus with a green environment. The Colleges are spread on a sprawling 60 acres of serene land. The Colleges are easily accessible from all major cities by road and railway networks.

These Institutions have emerged as a pioneer venture in the field of Technical Education. Dr.T.Arangannal – a Rashtria Vidhya Saraswathi Puraskar Awardee is the Chairman and Mrs.P.Malaleena is the Chairperson of the Educational Institutions.

GNANAMANI COLLEGE OF TECHNOLOGY

Gnanamani College of Technology is a leading Institution with state-of-the-art facility.

The institution is rendering noble service to the youths in rural and urban areas.

The college is accredited by the NAAC and NBA (CSE, ECE, EEE, and Mechanical). The college has grown in a short span of 16 years with 12 UG Courses namely Agricultural, Artificial Intelligence and Data Science, Bio-Medical, Biotechnology, Chemical, Computer Science, Electrical and Electronics, Electronics and Communication, Food Technology, Mechanical, Information Technology and Pharmaceutical Technology.

The Institute also offers 9 PG courses in Computer Science, Construction Engineering and Management, Environmental Engineering, Embedded System Technology, Power Electronics and Drives, Industrial Engineering, VLSI Design, BME, MBA and MCA.

INSTITUTE VISION

Emerging as a technical institution of high standard and excellence to produce quality Engineers, Researchers, Administrators and Entrepreneurs with ethical and moral values to contribute the sustainable development of the society.

INSTITUTE MISSION

We facilitate our students

- To have in-depth domain knowledge with analytical and practical skills in cutting edge technologies by imparting quality technical education.
- To be industry ready and multi-skilled personalities to transfer technology to industries and rural areas by creating interests among students in Research and Development and Entrepreneurship.

DEPARTMENT OF ELECTRICAL AND ELECTRONICS ENGINEERING

The Electrical and Electronics Engineering Department was started in the year 2006 and accredited by NBA in 2019. It offers B.E. with 60 student intake, M.E. – PED, M.E.—EST and Ph.D.in Full time and Part time modes. The department has 12 Curriculum Laboratories and 2 Industry supported labs providing 8 Value added courses and a Centre of Excellence – IOT Laboratory. Anna University recognized Research & Development Centre with 2 Ph.D., Supervisors and 4 Doctorates is fully functioning in the department since 2015. The faculty of the department have published more than 190+ reputed journal publications, 4 Patents and have received a project grant of 15 Lakh. The Department has 2 Professional Societies namely ISTE and IEI.

The Department of Electrical and Electronics Engineering (EEE) is committed to excellence in teaching, learning, research, and innovation. The department offers a strong academic foundation combined with practical exposure in emerging areas such as power systems, power electronics, electric vehicles, renewable energy, control systems, embedded systems, IoT, and VLSI. With well-qualified faculty, modern laboratories, and industry interaction, the department strives to produce competent engineers with professional ethics and social responsibility.

VISION

- Providing quality education for the sustainable development in the field of Electrical and Electronics Engineering to meet the global standards and to produce socially responsible engineers with ethical and moral values.

MISSION

- Imparting the quality technical education through state of the art infrastructure and modern tools.
- Making the students as professionals with ethical values, economical, ecological and social upliftment.
- Extending the sustainable knowledge through research and entrepreneurship for the benefits of humanities.

PROGRAM EDUCATIONAL OBJECTIVES

Graduates of Electrical and Electronics Engineering will

PEO-1: Have strong foundation in mathematics, science, and engineering fundamentals and advanced concepts towards their successful career in industries, research and entrepreneur.

PEO-2: Analyze, design and implement various electrical, electronics and interdisciplinary projects, addressing the industrial and social needs.

PEO-3: Have effective communication and leadership skills with ethical values.

PROGRAM SPECIFIC OUTCOMES

Graduates of the program will be able to

PSO-1: Attain in-depth knowledge and design skills in Electrical Power Systems, Electrical Drives, Power Electronics and Control, Electronics and Digital Electronics.

PSO-2: Acquire specialized skills in Solar Power Applications, High Voltage Engineering and competency for competitive examinations.

PROGRAM OUTCOMES

Engineering knowledge:

Apply the knowledge of mathematics, science, engineering fundamentals and an engineering specialization to the solution of complex engineering problems

Problem analysis:

Identify, formulate, review research literature, and analyze complex engineering problems reaching substantiated conclusions using first principles of mathematics, natural sciences and engineering sciences.

Design/development of solutions:

Design solutions for complex engineering problems and design system components or processes that meet the specified needs with appropriate consideration for the public health and safety, and the cultural, societal and environmental considerations.

Conduct investigations of complex problems:

Use research-based knowledge and research methods including design of experiments, analysis and interpretation of data and synthesis of the information to provide valid conclusions.

Modern tool usage:

Create, select, and apply appropriate techniques, resources, and modern engineering and IT tools including prediction and modeling to complex engineering activities with an understanding of the limitations.

The engineer and society:

Apply reasoning informed by the contextual knowledge to assess societal, health, safety, legal and cultural issues and the consequent responsibilities relevant to the professional engineering practice.

Environment and sustainability:

Understand the impact of the professional engineering solutions in societal and environmental contexts, and demonstrate the knowledge of, and need for sustainable development.

Ethics:

Apply ethical principles and commit to professional ethics and responsibilities and norms of the engineering practice.

A Individual and team work:

Function effectively as an individual and as a member or leader in diverse teams, and in multidisciplinary settings.

Communication:

Communicate effectively on complex engineering activities with the engineering community and with society at large, such as, being able to comprehend and write effective reports and design documentation, make effective presentations, and give and receive clear instructions.

Project management and finance:

Demonstrate knowledge and understanding of the engineering and management principles and apply these to one's own work, as a member and leader in a team, to manage projects and in multidisciplinary environments.

Life-long learning:

Recognize the need for, and have the preparation and ability to engage in independent and life-long learning in the broadest context of technological change.



MANAGEMENT PROFILE



Gnyanamani Educational Institutions are run by two legendary visionaries, Dr. T. Arangannal and Mrs. P. Malaleena, whose dedication to education has shaped the institution's identity and direction.

At the forefront is Dr. T. Arangannal, Chairman, a distinguished leader, who has been a driving force behind the institution's evolution. A recipient of the Rashtriya Vidya Saraswati Puraskar and an honorary Doctorate from the University of Sri Lanka, Dr. Arangannal is widely revered for his lifelong contributions to the field of education. His visionary leadership has cultivated a culture of excellence, discipline, and innovation across all levels of the institution.

Mrs. P. Malaleena, Chairperson, whose unwavering commitment and strategic foresight have been instrumental in establishing the institution's strong ethical and academic foundations. Her focus on student-centered learning and inclusive growth continues to define its mission, vision, and core values.

The leadership team also includes Ms. Madhuvanthinie Arangannal, Vice-Chairperson, who brings a contemporary vision and strategic insight to the institution's development. Her dynamic leadership focuses on aligning the institution with global academic standards and fostering innovation in education.

Operational administration is efficiently managed by Dr. P. Premkumar, Chief Administrative Officer, whose expertise in institutional management and policy implementation ensures the smooth functioning of all academic and support services. His strategic leadership plays a vital role in sustaining and enhancing the institution's quality standards.

Academic affairs are led by Dr. T.K. Kannan, Principal, who is committed to providing a rigorous and engaging academic environment. His leadership promotes research-driven teaching, skills development, and student empowerment, ensuring that learners are prepared to meet the demands of a rapidly changing global landscape.



CHAIRMAN'S MESSAGE



It gives me immense pleasure to express that our Electrical and Electronics Engineering release the department magazine for the academic year 2022-23 highlighting the various activities and budding talents of the students on this special occasion. I value the emerging ability and the endowment of the students in their articles, poems, drawing etc., which bloom out their young talents and skills. I appreciate our magazine committee for their venture in bring out this memorable edition.

I wish the Principal, Magazine Committee and the Editorial team, Staff and Students and all the hands that rendered service to bring out a fabulous magazine for this year, I am passionately waiting for the editorial team to reach another mile stone of perfection in the next magazine. I wish them all success.

Dr. T. Arangannal



CHAIRPERSON'S MESSAGE



I am glad to know that our Gnanamani College of Technology is leading a step forward by releasing the magazine 2022-2023. This magazine would be a common platform for the students to express their hidden talents and creativity. My hearty wishes to the Principal, staff members and students for the completion of this IGNITE.

Wishing you all success in their Academic Endeavours.

Tmt.P.Malaleena



VICE CHAIRPERSON'S MESSAGE



IGNITE is particularly important as it encourages the students to share the knowledge they have acquired. Writing articles for the magazine also improves the communication skills of the budding engineers of the EEE department. It is common knowledge that representation of an idea is as important as, if not more important, than the idea itself.

I would like to congratulate the faculty and the students of the editorial team on bringing out the issue of IGNITE and my best wishes to the students for a bright future.

Ms. Madhuvanthinie Arangannal



CAO'S MESSAGE



It is my privilege to know that Department of Electrical and Electronics Engineering releasing its achievements in a nutshell in the form of a magazine. This magazine is a skylight which always exhibit innovative and the creative thoughts of the blooming engineers. I take this opportunity to congratulate and wish all faculty members and students success.

Dr.P.Premkumar



PRINCIPAL'S MESSAGE



IGNITE represents a cloud with a silver lining for the world of technology. It aims to inspire and nurture upcome-world of technology. The magazine captures the current engineers to bring a revolution in this ever evolving technological advancements.

I would like to congratulate the vice principal, HoD, Staff members and students for bringing out the issue of IGNITE.

Dr. T.K. Kannan



HOD'S MESSAGE



Congratulations to the students and faculty associated to magazine committee for successfully publishing the issue of departmental technical magazine IGNITE. IGNITE is creating platform which provides an opportunity to the students and staff to express their original thoughts on technical topics.

The magazine plays an instrumental role in providing exposure to the students to develop written communication skills and command over the language. It is a step towards building professional and ethical attitude in them. The entire journey of creating IGNITE is an outcome of rigorous effort made by students and faculty.

On concluding note, I would like to thank all the stakeholders for their involvement and encouragement and wish all the best for their bright future.

Dr. J.Chandramohan

TABLE OF CONTENTS

Sl. No.	Topic	Activity Type	Presented by
1.	Wireless Power Transfer	Tech Knowledge	Dr.A.Venkatesh AP/EEE
2.	Vehicle-to-Grid (V2G) technology	Tech Knowledge	Mrs.M.Padmavathi AP/EEE
3.	Digital Substation	Tech Knowledge	R.Gokulraj IV/EEE
4.	Flexible AC Transmission	Tech Knowledge	V.Paulgideon III/EEE
5.	Smart Homes and Building Automation	Tech Knowledge	M. Balaji III/EEE
6.	Indian Army	Pencil Art	C.Sankar IV/EEE
7.	Penguin Paradise	Pencil Art	J.Yuvarani IV/EEE
8.	Lord Krishna	Pencil Art	S.Jayaseelan IV/EEE
9.	நட்பு	கவிதை	K.Vishnu Priya II/EEE
10.	காதல்	கவிதை	S. Sripriya II/EEE
11.	இயற்கை	கவிதை	V.Mohan Raj II/EEE
12.	அம்மா	கவிதை	S. Vignesh II/EEE
13.	Sundar Pichai	Biography	V.Shalini IV/EEE

Tech Knowledge

Wireless Power Transfer

Wireless Power Transfer (WPT) is an advanced technology that enables the transmission of electrical energy from a power source to an electrical device without the use of physical wires or direct electrical connections. This concept, once considered futuristic, has now become a practical solution in many modern applications. The basic idea of wireless power transfer is to deliver energy through electromagnetic fields, eliminating the need for conventional conductive paths such as cables. This technology not only enhances convenience but also improves safety and reliability in various systems. As the demand for portable devices and efficient energy systems increases, WPT is gaining significant importance in both academic research and industrial applications.

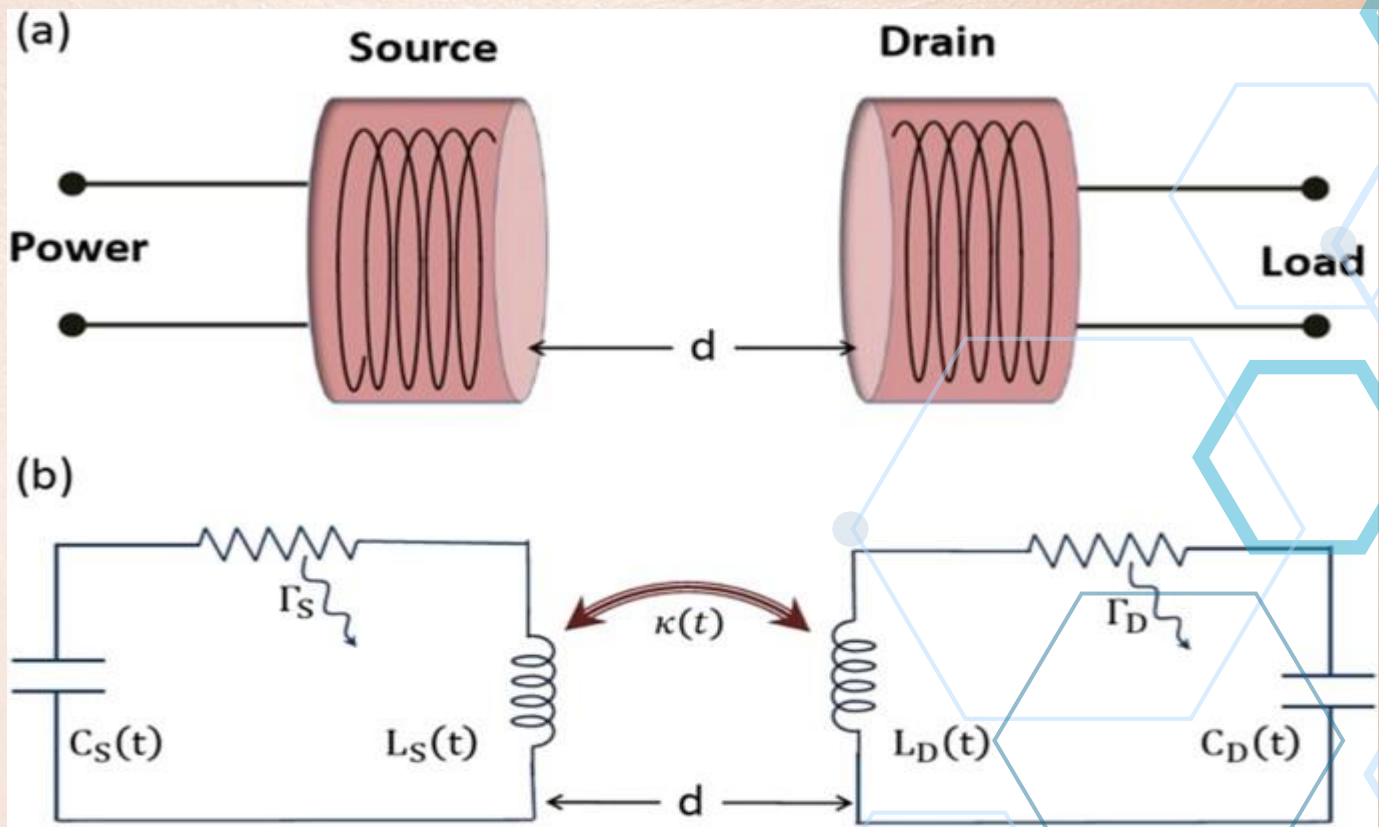

The working principle of wireless power transfer is mainly based on electromagnetic theories. There are three primary methods used in WPT: electromagnetic induction, resonant inductive coupling, and electromagnetic radiation. In electromagnetic induction, energy is

transferred between two coils—a transmitter coil and a receiver coil—through a magnetic field. When alternating current flows through the transmitter coil, it generates a changing magnetic field, which induces a voltage in the receiver coil placed nearby. This method is highly efficient for short distances and is widely used in applications like wireless charging pads for smartphones and electric toothbrushes.

Resonant inductive coupling is an improved version of inductive coupling. In this method, both the transmitter and receiver coils are tuned to the same resonant frequency. This allows energy to be transferred more efficiently over a greater distance compared to simple inductive coupling. Resonance reduces energy loss and improves the overall performance of the system. This technique is particularly useful in applications such as wireless charging of electric vehicles and large electronic devices, where a slightly longer distance between the source and load is required.

Another method of wireless power transfer is electromagnetic radiation, which includes microwave and laser-based power transmission. In this approach, electrical energy is converted into electromagnetic waves and transmitted through space. At the receiving end, these waves are captured and converted back into electrical energy. Although this method can transfer energy over long distances, it is less efficient and requires precise alignment and safety measures. It is mainly used in specialized applications such as satellite power systems and space-based solar power transmission.

Wireless power transfer systems consist of several important components, including a power source, a transmitter, a coupling mechanism, and a receiver. The transmitter converts electrical energy into an electromagnetic field, which is then transmitted through space. The receiver captures this energy and converts it back into usable electrical power. Additional circuits such as rectifiers, filters, and control units are often used to ensure stable and efficient energy transfer. Proper design of these components is essential to achieve high efficiency and reliability.

Dr.A.VENKATESH AP/EEE

Vehicle-to-Grid (V2G) technology

Vehicle-to-Grid (V2G) technology is an innovative concept that enables electric vehicles (EVs) to not only draw power from the electrical grid but also supply excess stored energy back to it. Traditionally, vehicles have been seen only as energy consumers, but with the advancement of electric mobility and smart grid systems, EVs are now being transformed into mobile energy storage units. V2G technology plays a significant role in enhancing energy management, improving grid stability, and supporting the integration of renewable energy sources. It represents a major step toward the development of sustainable and intelligent power systems. The basic principle of V2G technology lies in bidirectional power flow between the electric vehicle and the power grid. In this system, electric vehicles are equipped with special bidirectional chargers that allow electricity to flow in both directions. When the vehicle is charging, power flows from the grid to the battery. Conversely, when the grid requires additional power—especially during peak demand periods—the stored energy in the EV battery can be fed back into the grid. This interaction is managed through advanced control systems, communication networks, and smart metering infrastructure, ensuring efficient and safe operation.

A key component of V2G systems is the bidirectional charger, which acts as both a charger and an inverter. It converts alternating current (AC) from the grid into direct current (DC) to charge the battery and converts DC back into AC when supplying energy to the grid. In addition, communication systems such as smart meters and grid controllers play a crucial role in monitoring energy flow, battery status, and grid requirements. These systems use advanced algorithms to decide when to charge or discharge the vehicle, optimizing both user convenience and grid performance. One of the major advantages of V2G technology is its ability to support grid stability. During periods of high electricity demand, such as evenings or extreme weather conditions, the grid can experience stress or overload. V2G-enabled vehicles can supply additional power to reduce this burden, helping to prevent blackouts and maintain a stable power supply. Similarly, during low demand periods, vehicles can be charged, ensuring efficient utilization of energy resources. This dynamic interaction helps balance supply and demand in the power system.

Another important benefit of V2G technology is its role in integrating renewable energy sources like solar and wind power. Renewable energy generation is often intermittent and unpredictable, leading to fluctuations in power supply. Electric vehicles can act as distributed energy storage systems, storing excess renewable energy when production is high and supplying it back to the grid when production is low. This improves the reliability and efficiency of renewable energy systems and reduces dependence on fossil fuels. V2G technology also offers economic benefits to EV owners. By participating in energy trading, vehicle owners can earn incentives or reduce their electricity costs by selling stored energy back to the grid during peak demand periods. Utility companies may offer financial compensation or lower tariffs to encourage participation in V2G programs. This creates a win-win situation where both consumers and power providers benefit from improved energy management.

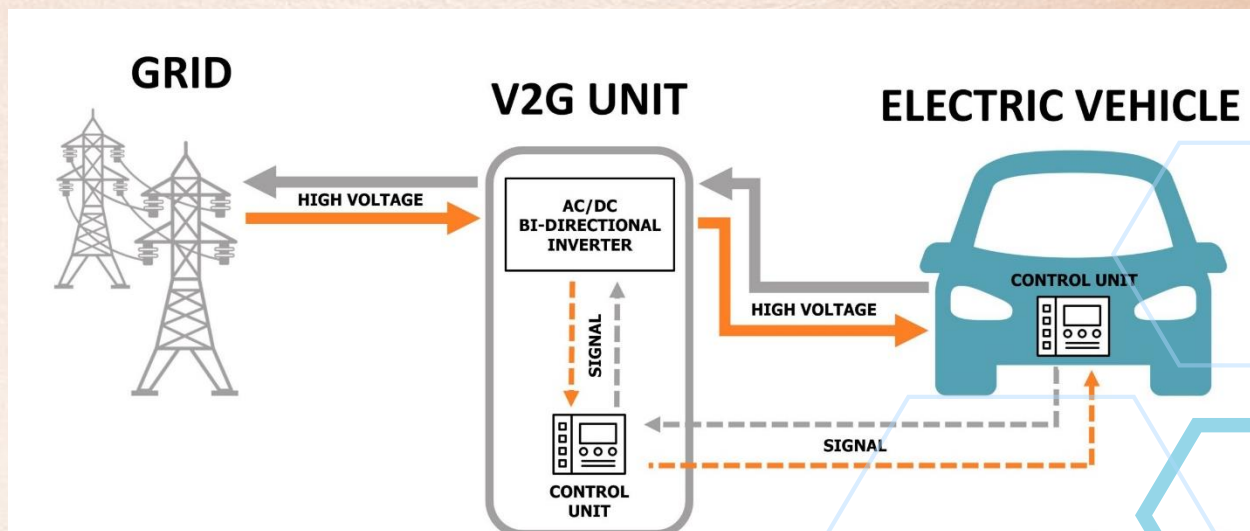

In addition to grid support, V2G technology can be used for emergency power supply. In case of power outages or natural disasters, electric vehicles can serve as backup power sources for homes, hospitals, and critical infrastructure. This enhances energy resilience and provides an additional layer of security in emergency situations. The ability to use EVs as portable power units makes them highly valuable in disaster-prone areas.

Mrs.M.PADMAVATHI AP/EEE

Digital Substation

A digital substation is a modern approach to electrical power system design that replaces conventional hardwired connections with intelligent electronic devices (IEDs) and high-speed communication networks. In traditional substations, large bundles of copper cables are used to transmit analog signals between equipment such as current transformers, voltage transformers, protection relays, and control panels. Digital substations, on the other hand, convert these analog signals into digital data at the source using merging units, and then transmit the data over fiber-optic communication networks. This transformation significantly reduces wiring complexity, installation costs, and maintenance requirements while improving accuracy and reliability.

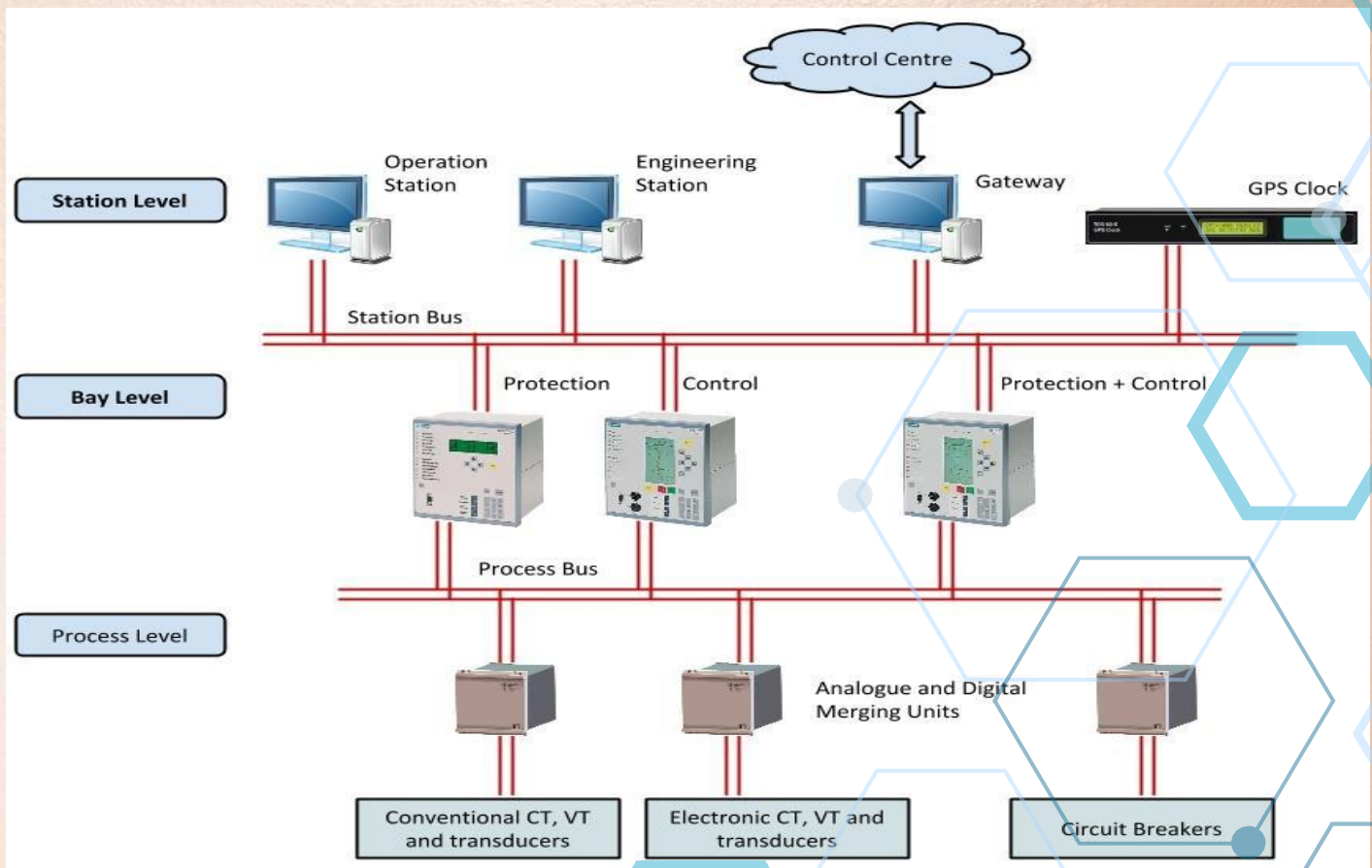

One of the key technologies enabling digital substations is the IEC 61850 communication standard, which provides a unified framework for data exchange between substation devices. It ensures interoperability among equipment from different manufacturers and supports advanced features such as real-time monitoring, automation, and remote control. Process bus

and station bus architectures are commonly used in digital substations to facilitate communication between primary equipment and control systems. The process bus carries real-time sampled values and status information, while the station bus connects higher-level control, protection, and monitoring systems. Digital substations offer several advantages over conventional substations, including enhanced operational efficiency, improved safety, and better system flexibility. The use of fiber-optic communication minimizes electromagnetic interference and increases data transmission speed. Additionally, digital systems enable predictive maintenance by continuously monitoring equipment health and detecting faults early. This leads to reduced downtime and improved asset management. Digital substations also support the integration of renewable energy sources and smart grid technologies, making them a crucial component of modern power systems. Despite challenges such as cybersecurity concerns and higher initial investment, the long-term benefits of digital substations make them an essential evolution in electrical infrastructure.

R.GOKULRAJ
IV YEAR



Flexible AC Transmission

Flexible AC Transmission Systems (FACTS) refer to a collection of advanced power electronic-based devices used in electrical power systems to enhance the controllability, stability, and power transfer capability of AC transmission networks. With the growing demand for electricity and the increasing complexity of modern power systems, traditional transmission networks often face challenges such as voltage instability, power oscillations, and transmission congestion. FACTS devices provide an effective solution to these issues by dynamically controlling key electrical parameters like voltage, impedance, and phase angle, thereby improving the overall performance and efficiency of the power system.

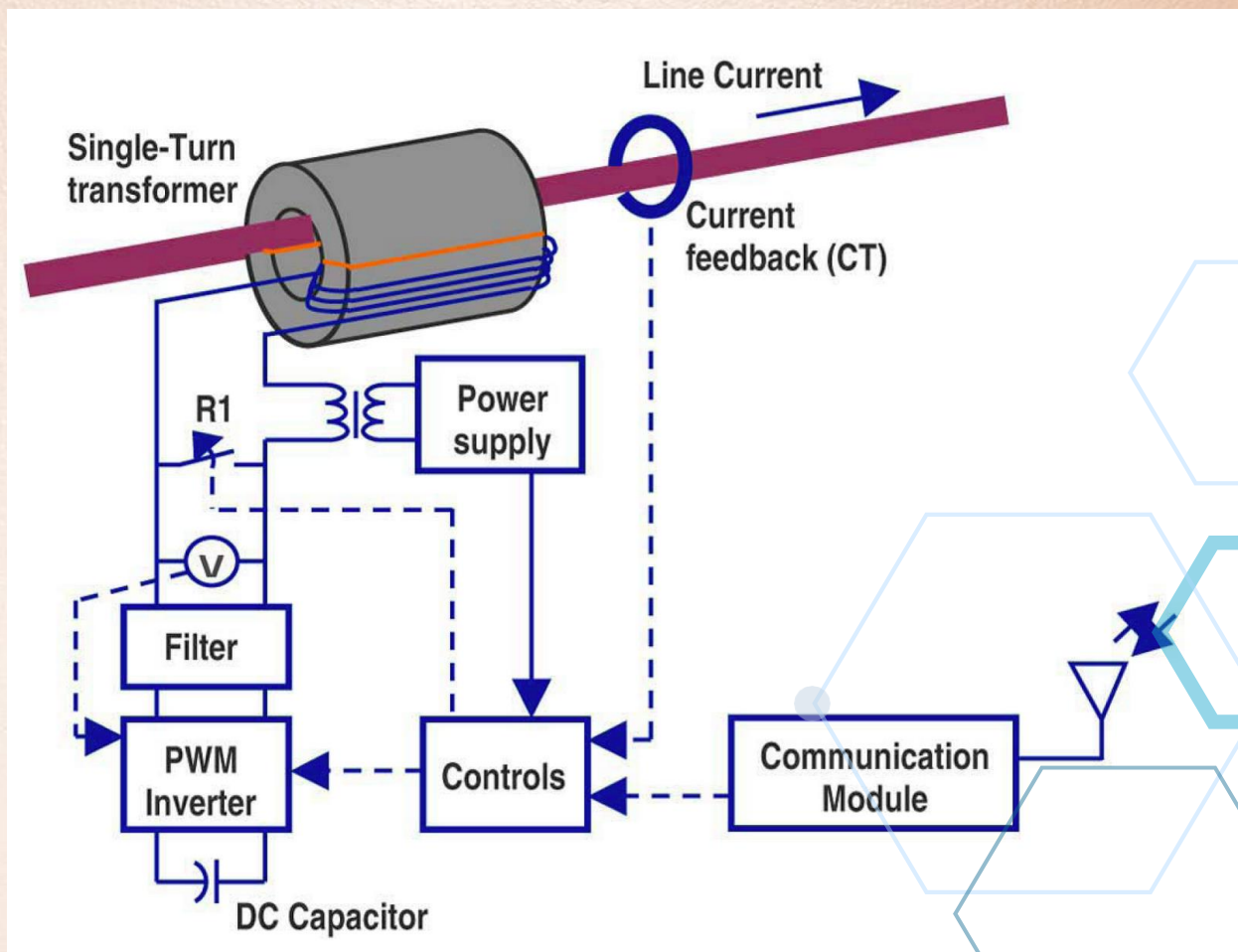

These devices include thyristors, gate turn-off thyristors (GTOs), and insulated gate bipolar transistors (IGBTs), which enable rapid switching and precise control of electrical power. FACTS controllers can be broadly classified into three categories based on their connection in the power system: shunt controllers, series controllers, and combined controllers.

Shunt controllers are connected in parallel with the transmission line and are mainly used for voltage regulation and reactive power compensation. Examples include the Static VAR Compensator (SVC) and the Static Synchronous Compensator (STATCOM). These devices help maintain voltage levels within acceptable limits, especially during sudden load changes or fault conditions. By injecting or absorbing reactive power, shunt controllers improve the voltage profile and enhance system stability. Series controllers, on the other hand, are connected in series with the transmission line and are used to control line impedance and power flow. Devices such as the Thyristor Controlled Series Capacitor (TCSC) and Static Synchronous Series Compensator (SSSC) fall under this category. These controllers can increase or decrease the effective reactance of the transmission line, thereby controlling the amount of power flowing through it. This helps in reducing transmission losses, mitigating power oscillations, and preventing line overloading.

Combined controllers integrate both series and shunt compensation techniques to provide comprehensive control over power system parameters. A prominent example is the Unified Power Flow Controller (UPFC), which is one of the most versatile FACTS devices. It can simultaneously control voltage, impedance, and phase angle, making it highly effective for managing power flow and enhancing system stability. The Interline Power Flow Controller (IPFC) is another combined controller that manages power flow across multiple transmission lines. FACTS devices offer numerous advantages in modern power systems. They increase the power transfer capability of existing transmission lines without the need for constructing new lines, thereby reducing environmental impact and cost. They improve system stability by damping power oscillations and preventing voltage collapse. FACTS also enhance power quality by reducing flicker and maintaining voltage levels. Additionally, they enable better integration of renewable energy sources such as wind and solar power, which are often variable and unpredictable in nature.

V.PAULGIDEON
III YEAR

Smart Homes and Building Automation

Smart homes and building automation refer to the integration of advanced technologies, communication systems, and intelligent control mechanisms to enhance the comfort, security, energy efficiency, and convenience of residential and commercial buildings. With the rapid development of the Internet of Things (IoT), artificial intelligence, and wireless communication, traditional buildings are being transformed into smart environments where devices and systems can communicate with each other and be controlled remotely. In a smart home, various appliances such as lighting systems, heating, ventilation, and air conditioning (HVAC), security systems, and entertainment devices are interconnected through a central control system, allowing users to monitor and manage them using smartphones or computers.



One of the key features of smart homes is automation, where routine tasks are performed automatically based on predefined conditions or user preferences. For example, lights can be programmed to turn on or off depending on occupancy or time of day, and thermostats can adjust temperature settings based on weather conditions or user habits. Devices like Amazon Echo and Google Nest Thermostat play an important role in enabling voice control and

intelligent temperature regulation. These systems not only provide convenience but also help in reducing energy consumption by optimizing the use of electrical appliances.

Building automation extends the concept of smart homes to larger infrastructures such as offices, hospitals, shopping malls, and industrial buildings. It involves centralized control of various building systems including lighting, HVAC, fire safety, elevators, and security systems. A Building Management System (BMS) is commonly used to monitor and control these operations in real time. Sensors are widely deployed to collect data such as temperature, humidity, motion, and light intensity, which is then processed to make intelligent decisions. For instance, HVAC systems can be automatically adjusted based on occupancy levels, thereby improving energy efficiency and reducing operational costs.

Security is another major advantage of smart homes and building automation systems. Smart security systems include surveillance cameras, motion detectors, smart locks, and alarm systems that can be monitored remotely. Users receive real-time alerts in case of unauthorized access or unusual activity, ensuring better safety. Integration with mobile applications allows homeowners and facility managers to control access, view live video feeds, and respond quickly to emergencies. Additionally, fire detection and gas leakage systems can automatically trigger alarms and notify authorities, enhancing overall safety.

Energy management is a critical aspect of smart buildings. Automation systems help in reducing energy wastage by ensuring that electrical devices operate only when needed. Smart meters and energy monitoring systems provide detailed insights into energy consumption patterns, enabling users to take informed decisions. Renewable energy sources such as solar panels can also be integrated with smart systems to optimize energy usage and reduce dependence on conventional power sources. This contributes to environmental sustainability and cost savings.

PENCIL ART

INDIAN ARMY



**SANKAR C
IV YEAR**

Penguin Paradise

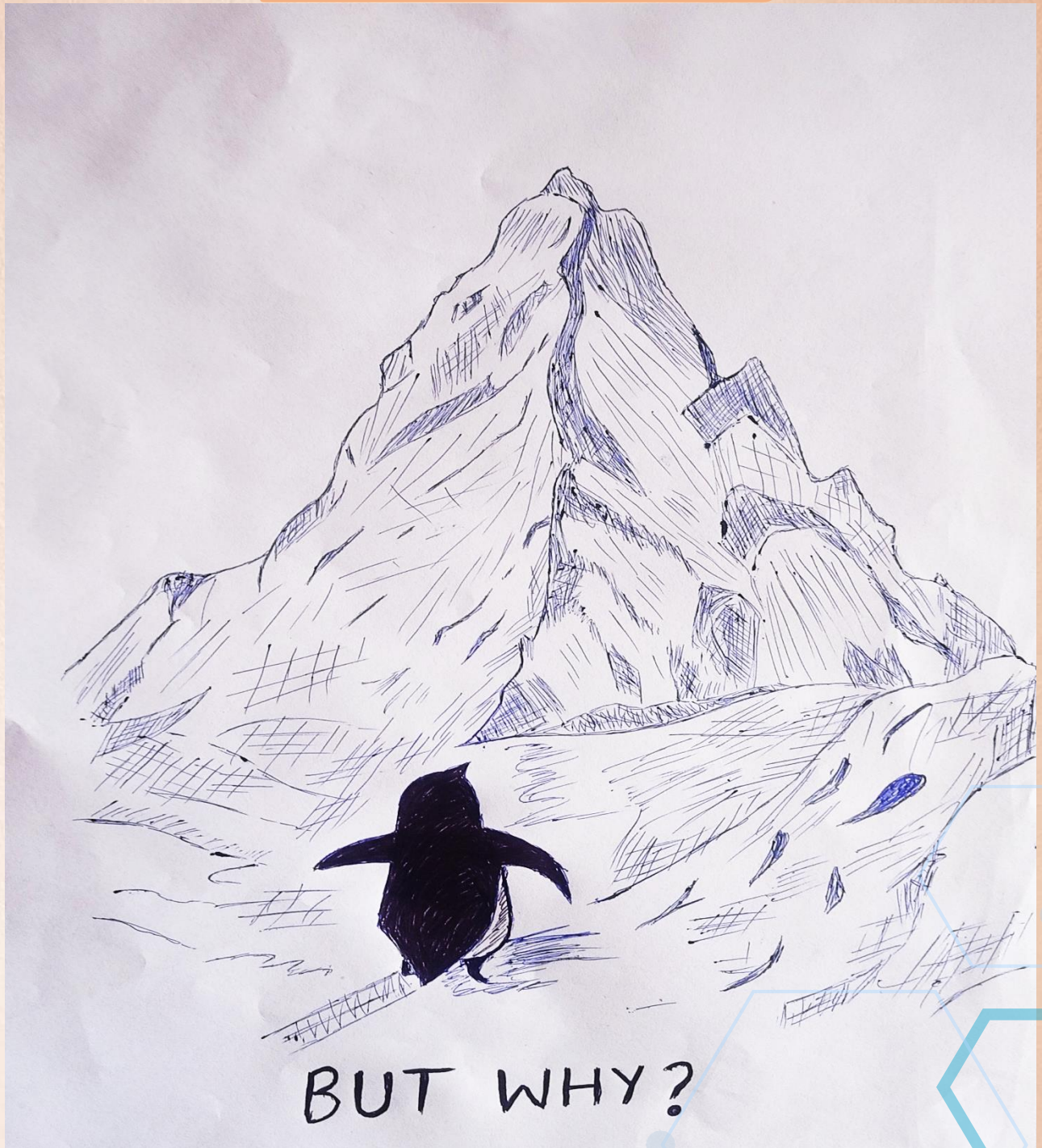

J.YUVARANI
IV YEAR

LORD KRISHNA

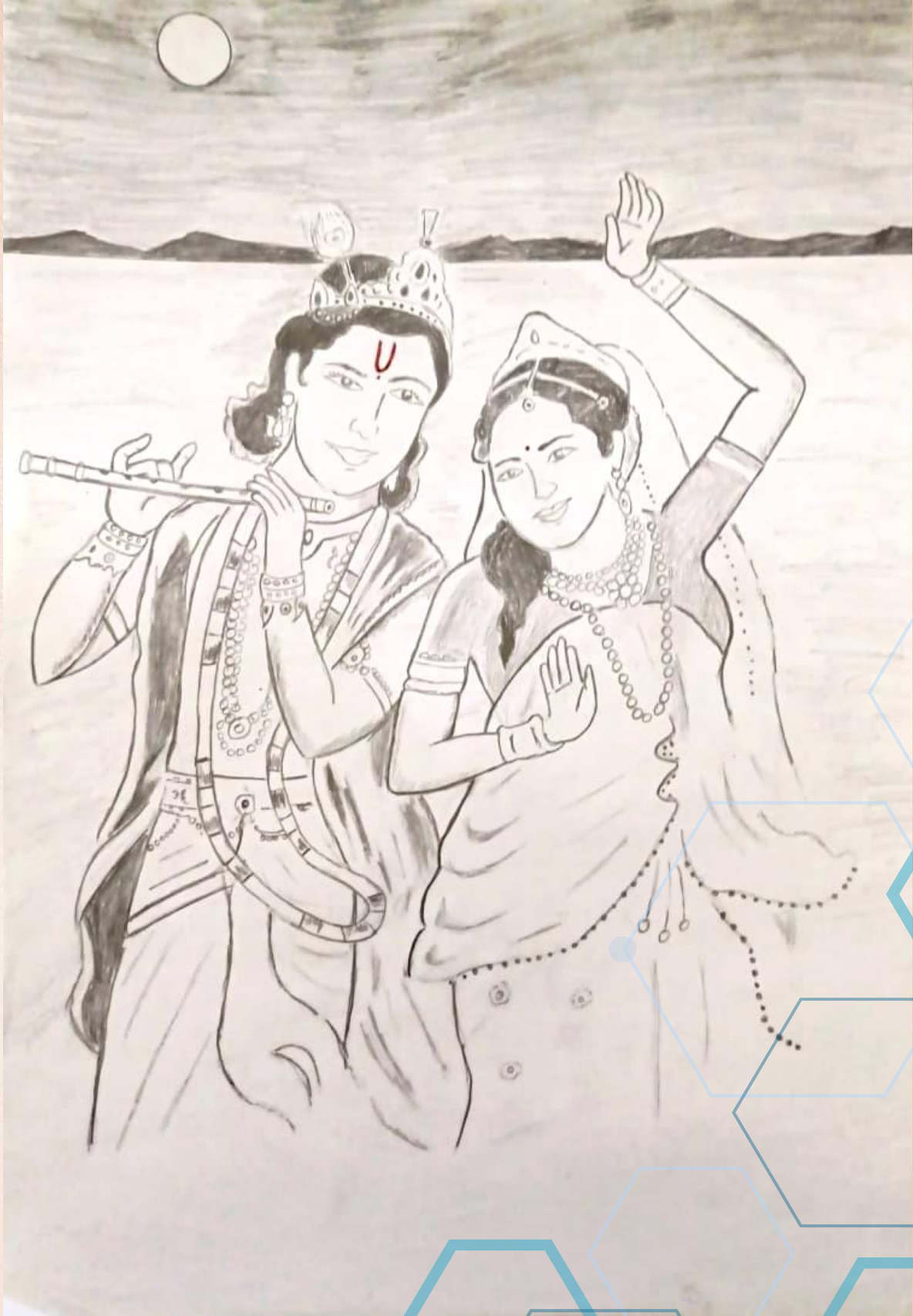

S.Jayaseelan

IV YEAR

POEMS

நட்பு

சிரிப்பில் தொடங்கும் உறவு,
சோகத்தில் துணையும் நட்பு,
வார்த்தைகள் இல்லாவிட்டாலும்
மனதை புரியும் பாசம்.
தவறுகள் வந்த நேரமும்
தள்ளி விடாத உறவு,
வாழ்க்கை முழுதும் நிழலாய்
வந்திடும் அழகான நட்பு.

காதல்

உன் பார்வை பேசும் கவிதை,
உன் சிரிப்பு இனிய இசை,
நினைத்தாலே மனம் மலரும்
நிலவொளி போன்ற அழகு.
நேரம் எல்லாம் நின்றுபோல்
நீ அருகில் வந்தால்,
என் இதயம் முழுவதும்
உன் பெயரே ஒலிக்கிறது.

VISHNU PRIYA K
II YEAR

SRIPRIYA S
II YEAR

இயற்கை

காலை பனி முத்தமிட்டு,
காற்று வந்து பாடுகிறது,
மலர்கள் எல்லாம் சிரித்தபடி
மண்ணின் வாசம் வீசுகிறது.

ஆறு ஓசை இசையாய்,
பறவைகள் கனவாய்,
இயற்கையின் மடியிலே
இன்பம் தினம் மலர்கிறது.

MOHAN RAJ V
II YEAR

அம்மா

உன் அன்பு ஒரு நிழலடி,
உன் வார்த்தை என் வழிகாட்டி,
கண்ணீரில் கூட சிரிப்பைக் கற்றாய்,
கஷ்டத்தில் துணிவை விதைத்தாய்.

உன் கைகள் என் பாதுகாப்பு,
உன் மனம் என் சொர்க்கம்,
எத்தனை ஜென்மம் எடுத்தாலும்
உனக்கே நான் குழந்தை தான்.

VIGNESH S
II YEAR

BIOGRAPHY

Sundar Pichai

Sundar Pichai was born on June 10, 1972, in Madurai, Tamil Nadu, India. His full name is Pichai Sundararajan. He was raised in a middle-class family in Chennai, where his father worked as an electrical engineer and his mother was a stenographer. From a young age, Sundar Pichai showed great interest in technology and education. He had an excellent memory and was very talented in academics, especially in mathematics and science. Even during his school days, he was known for his calm nature, intelligence, and determination to succeed. His parents encouraged him to study well and supported his dreams despite financial difficulties.



Sundar Pichai completed his schooling at Jawahar Vidyalaya and later at Vana Vani School in Chennai. After finishing school, he joined the Indian Institute of Technology (IIT) Kharagpur to study Metallurgical Engineering. During his college days, he became one of the brightest students in his batch and received a silver medal for academic excellence. His professors recognized his talent and encouraged him to pursue higher studies abroad. Later, he moved to the United States to continue his education at Stanford University, where he studied Materials Science and Engineering. Going to America was not easy for his family because of financial challenges, but his parents made many sacrifices for his education. Sundar Pichai worked hard and made the best use of every opportunity he received.

After completing his studies at Stanford University, he pursued an MBA from the Wharton School of the University of Pennsylvania. He was honored as both a Siebel Scholar and a Palmer Scholar because of his outstanding academic performance. Before joining Google, Sundar Pichai worked at Applied Materials and later at McKinsey & Company as a management consultant. These experiences helped him gain knowledge in business management and technology industries. However, his life changed completely when he joined Google in 2004. At Google, he initially worked on the Google Toolbar project. His ideas and leadership skills impressed senior executives, and he gradually became an important part of the company.

One of Sundar Pichai's greatest achievements was leading the development of Google Chrome, which later became the world's most popular web browser. Many people were unsure whether creating a new browser would succeed, but Sundar Pichai believed in innovation and teamwork. Under his leadership, Chrome became highly successful because of its speed, simplicity, and security. He also played a major role in the development of products such as Gmail, Google Maps, and Android. His ability to understand users' needs and lead teams effectively made him one of the most respected leaders in the technology world. In 2015, Sundar Pichai was appointed as the Chief Executive Officer (CEO) of Google. Later, in 2019, he also became the CEO of Alphabet Inc., the parent company of Google. His leadership brought many innovations in artificial intelligence, cloud computing, and digital technology. Despite becoming one of the most powerful business leaders in the world, Sundar Pichai remained humble and simple in his lifestyle. He often speaks about the importance of education, hard work, patience, and positive thinking. His journey from a simple home in Chennai to becoming the CEO of one of the world's biggest technology companies inspires millions of students and young professionals across the world.

SHALINI.V
IV YEAR

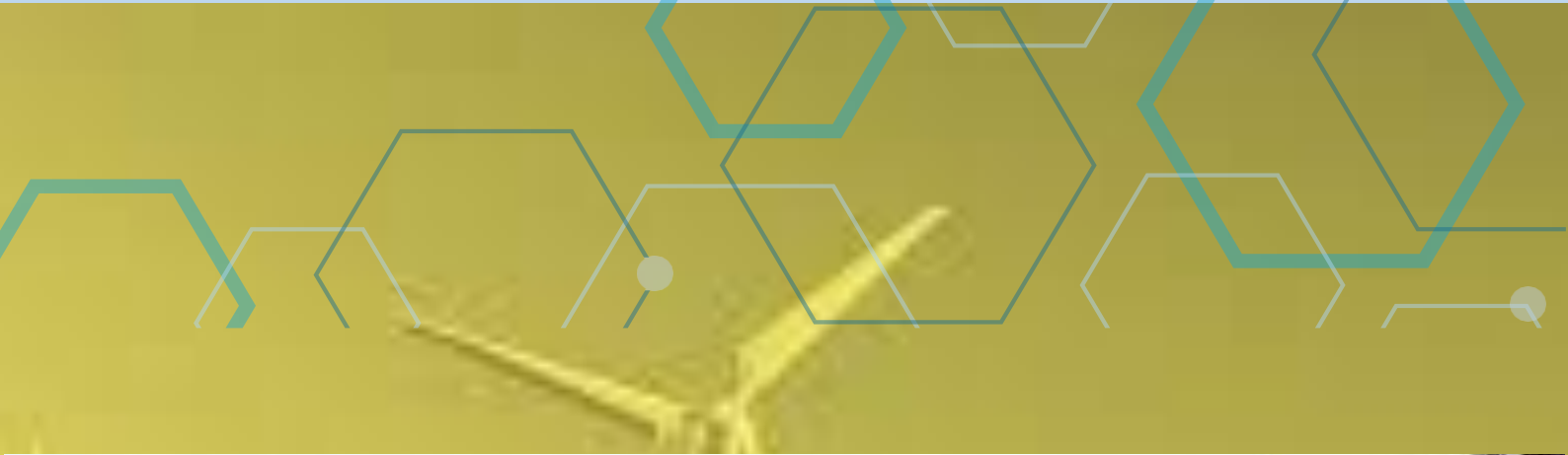

AI is probably the most important thing humanity has ever worked on. I think of it as something more profound than electricity or fire.

-Sundar Pichai